



POWER PLANT – RELAY REPLACEMENT DESIGN



ISU Senior Design Group: Dec15-22

Dan Dye

Project Web Site:

<http://dec1522.sd.ece.iastate.edu/>

Project Sponsor: CIPCO

Project Advisor: Professor Mani Mina

Revised: 4/25/15

Table of Contents:

- 1. Project Statement 4
 - 1.1. Project Description..... 4
 - 1.2. Project Scope 4
 - 1.2.1. Relay Replacement 4
 - 1.2.2. Arc Flash Calculations and Analysis 4
 - 1.2.3. Safe Operation of Metal Clad Switchgear 4
 - 1.3. Excluded From the Project..... 4
 - 1.3.1. Design Simulation and Testing 4
 - 1.3.2. Relay Settings 4
 - 1.3.3. Relay Testing 5
 - 1.3.4. Procurement 5
 - 1.4. Project Deliverables 5
 - 1.4.1. Spring Semester 2015 Deliverables 5
 - 1.4.2. Fall Semester 2015 Deliverables..... 5
 - 1.5. Design Specifications..... 6
 - 1.5.1. Operating Environment..... 6
 - 1.5.2. Compliance Standards..... 6
 - 1.5.3. Standards..... 6
 - 1.6. Risk 6
- 2. System Level Design 7
 - 2.1. System Requirements and Functional Decomposition 7
 - 2.1.1. Function Requirements 7
 - 2.1.2. Non-Functional Requirements 7
 - 2.2. System Analysis..... 8
 - 2.2.1. Block Diagram of the Concept..... 8
- 3. Design Description..... 8
 - 3.1. System input/output Analysis 9
 - 3.1.1. System Inputs..... 9
 - 3.1.2. System Outputs 9
 - 3.2. User Interface Specifications 9
 - 3.3. Hardware/software Specifications 9
 - 3.4. Simulations and Modeling 9
 - 3.5. Implementation Issues Challenges..... 9

- 3.6. Testing, Procedures and Specifications 9
- 4. Design Decisions and Justifications..... 9
 - 4.1. One Line Diagram..... 10
 - 4.2. Elementary / Current Diagram 10
 - 4.3. Control Diagram 11
 - 4.4. Panel Wiring 11
 - 4.5. Communication Wiring..... 12
- 5. Work Plan 13
- 6. Conclusion 13
- 7. Engineering Diagrams 14
 - 7.1. Switch Gear Diagrams 14
 - 7.1.1. One Line Diagram..... 14
 - 7.1.2. Power Plant – Unit #6 Diagram 15
 - 7.2. Standard Drawings 15
 - 7.2.1. Title Block 15
 - 7.2.2. Standard Relay Wiring Diagram..... 15
 - 7.2.3. CIPCO AutoCAD Standard Summary..... 16

Figures and Diagrams:

- Figure 1: Concept Block Diagram 8
- Figure 2: One Line Diagram 10
- Figure 3: Elementary / Current Diagram 10
- Figure 4: Control Diagram..... 11
- Figure 5: Panel Wiring..... 12
- Figure 6: Communication Wiring 12
- Figure 7: One Line Diagram 14
- Figure 8: Connection Diagram / Wiring Schematic..... 15
- Figure 9: Standard Title Block..... 15
- Figure 10: Standard Relay Wiring Diagram 15

Tables:

- Table 1: Work Schedule - Gantt chart 13

1. Project Statement

1.1. Project Description

There are three main parts to this project. First, due to age and condition the existing power plant electro-mechanical relay equipment will be retired and new microprocessor based relaying equipment will be installed. The senior design project will be responsible for the complete design of the relay replacement which includes all required schematics and wiring diagrams.

Second, the senior design project will complete arc flash calculations and analysis for the existing metal clad switch gear. Metal clad switch gear has been known in the industry to have a high potential for arc flash. Determining the potential of these issues allows the operator to be aware and use the proper amount of precaution and personal protective equipment.

Third, the senior design project will provide engineering solutions to operate the switch gear safely. By researching alternatives and analysis of the potential of arc flash, engineering solutions shall be provided to advice in choosing the proper safety precautions during operations.

1.2. Project Scope

1.2.1. Relay Replacement

The primary goal of this project is to replace four power plant electromechanical relays with microprocessor based SEL relays. A full set of for-construction drawings will be completed showing the remove and addition of equipment and wiring, including communication equipment. The drawings will be completed using existing drawings while following CIPCO drafting standards and design templates. Relay functions for this situation will be identified and described.

1.2.2. Arc Flash Calculations and Analysis

The second part of this project is to complete arc flash calculations and analysis. These will be used to show the potential of an arc flash on metal clad switch gears which are controlled by the relay equipment that will be replaced.

1.2.3. Safe Operation of Metal Clad Switchgear

The third part of this project will be to identify two engineering solutions to operate the metal clad switch gear and relay equipment safely. Cost estimates and benefits of both solutions will be reviewed.

1.3. Excluded From the Project

1.3.1. Design Simulation and Testing

While all due diligence will be given during the design of this project, simulation and testing will not be completed as part of this project. Verification of design documentation will be completed during design review meetings with CIPCO.

1.3.2. Relay Settings

Relay settings will not be included as part of the relay replacement. Identification of suggested relay functions will be included.

1.3.3. Relay Testing

Microprocessor based relays require very precise testing due to the amount of features and internal programming. Relay tests or system check out procedure will not be provided as part of this senior design project.

1.3.4. Procurement

Equipment and materials will not be procured for this project. A bill of material list and cost estimates will be provided.

1.4. Project Deliverables

The following list of requirements were established with CIPCO and in accordance with CIPCO document "Project Scope" included under section design documents. The template for the CIPCO Project Scope was provided by CIPCO. These deliverables will be included in the form of for construction drawings, a document called Arc Flash, and document called Safe Operation of Metal Clad Switch Gear.

1.4.1. Spring Semester 2015 Deliverables

Relay Replacement

- Relay one line diagram
- Elementary diagram / current schematic
- Control schematic
- Panel wiring
- Communication processor wiring
- Drafting and review

Arc Flash Calculation

- Calculation per O.S.H.A. (Occupational Safety & Health Administration)

Safe Operation of Metal Clad Switch Gear

- Research and identify two possible engineering solutions
- Pros and cons of both solutions

1.4.2. Fall Semester 2015 Deliverables

Relay Replacement

- For construction package
- Relay functions

Arc Flash Analysis

- Calculation analysis
- Compliance regulations

Safety Operation Solutions

- Compliance regulation
- Cost estimates
- Operation guides

1.5. Design Specifications

As stated, the existing electro-mechanical relays are being replaced due to age and condition. The new SEL 351 relays are microprocessor based and which has many benefits over electro-mechanical style relays, such as the following:

- Higher level of flexibility of protection schemes
- More inputs and outputs for greater control and room for expansion
- Faster and more precise relay testing
- Communication to monitor and gather data

The new SEL relays give overall flexibility and room to grow as protection needs and technology change.

1.5.1. Operating Environment

The operating environment will be considered for each part of the project due to the harsh power plant environment. The environment can have large temperature changes along with dust, vibration, audio and electrical noise. These, among other operating constraints, will be considered during the design of this project.

1.5.2. Compliance Standards

Compliance standards play a large part in all aspects of the electric utility business and operation. These compliance standards will be ever present in all aspects of this project

OSHA

Occupational Safety and Health Administration (OSHA) standard 29 CFR Parts 1910 & 1920 Electric Power Generation, Transmission, and Distribution. This standard helps setup rules and standards to promote safety in the electric utility industry.

NERC

North American Electric Reliability Corporation (NERC) standards are in place to help protect the reliability of the electric system. These standards are highly important and full compliance is required.

1.5.3. Standards

Design and CAD standards

CIPCO design and CAD standards will be followed during the design of this project. These design standards are in place to insure the equipment is designed properly, and to help prevent field installation problems, and ease of design and checkout.

1.6. Risk

This project involves many areas of risk. While designing this project the designer will have to take into account these risks and design around them. Some of these areas of risk are operating environment, complying with compliance standards, budgetary constraints, and meeting project deadlines. During the design, the designer will need to build in protection from these risks.

2. System Level Design

This project consists of relay replacements on 4 sets of metal clad switch gear on panel units 6,7,8, and 9. The existing electromechanical relays are to be replaced with SEL 351 relays. Arc Fault calculations and engineered safety operation alternatives will be determined to operate the switchgear. The calculations will follow OSHA 29 CFR 1910.269 standard.

2.1. System Requirements and Functional Decomposition

2.1.1. Function Requirements

Due to the properties of this project, there will be no physical deliverables to test the functionality. The project will be designed to meet the main project requirements while adhering to CIPCO and regulatory standards. That being said, the reviews completed by the project sponsor will help insure that the designer is working towards producing a proper design that will function as required after implementation. Therefore, the following are considered functional requirements of this design project:

- Development of engineering for construction drawing package in AutoCAD format for relay replacement including the following:
 - Relay one line diagram
 - Elementary diagram / current schematic
 - Control schematic
 - Panel wiring
 - Communication processor wiring
 - All required drafted
 - Proposed relay functions
- Arc flash calculations and analysis
 - Per OSHA standard 29 CFR 1910.269
 - Calculation analysis and safety recommendations
- Safe operation of metal clad switch gear
 - Two possible engineering solutions to safely operated switchgear
 - Analysis of compliance regulation
 - Cost estimates
 - Operations guides for solutions

2.1.2. Non-Functional Requirements

Due to this project being a design without implementation, there are no non-functional requirements. This is primarily due to the project exceptions of relay modeling and testing. The project will be designed to meet all standards to insure the equipment will function as required when installed and tested. The functionality and relay settings will be tested at installation and is out of scope for this project.

2.2. System Analysis

2.2.1. Block Diagram of the Concept

To help stay organized, produce a high quality product, and keep on track the relay replacement design has been broken down into several parts. Each step has a review process with the Terry Fett, the Project Sponsor from CIPCO and the Supervisor of the Engineering Department, to insure the right approach has been taken with the design. During the review process, drawings will be delivered to Terry Fett. He will review and comment on the drawings. The drawings will then be delivered back to the designer for corrections. This process continues until Terry has deemed the design correct and then the designer can move on to the next step. This early and often approach prevents mistakes from being carried throughout the project making corrections far more complicated, time consuming, and costly. This review process follows closely how CIPCO operates with internal and external design consultants.

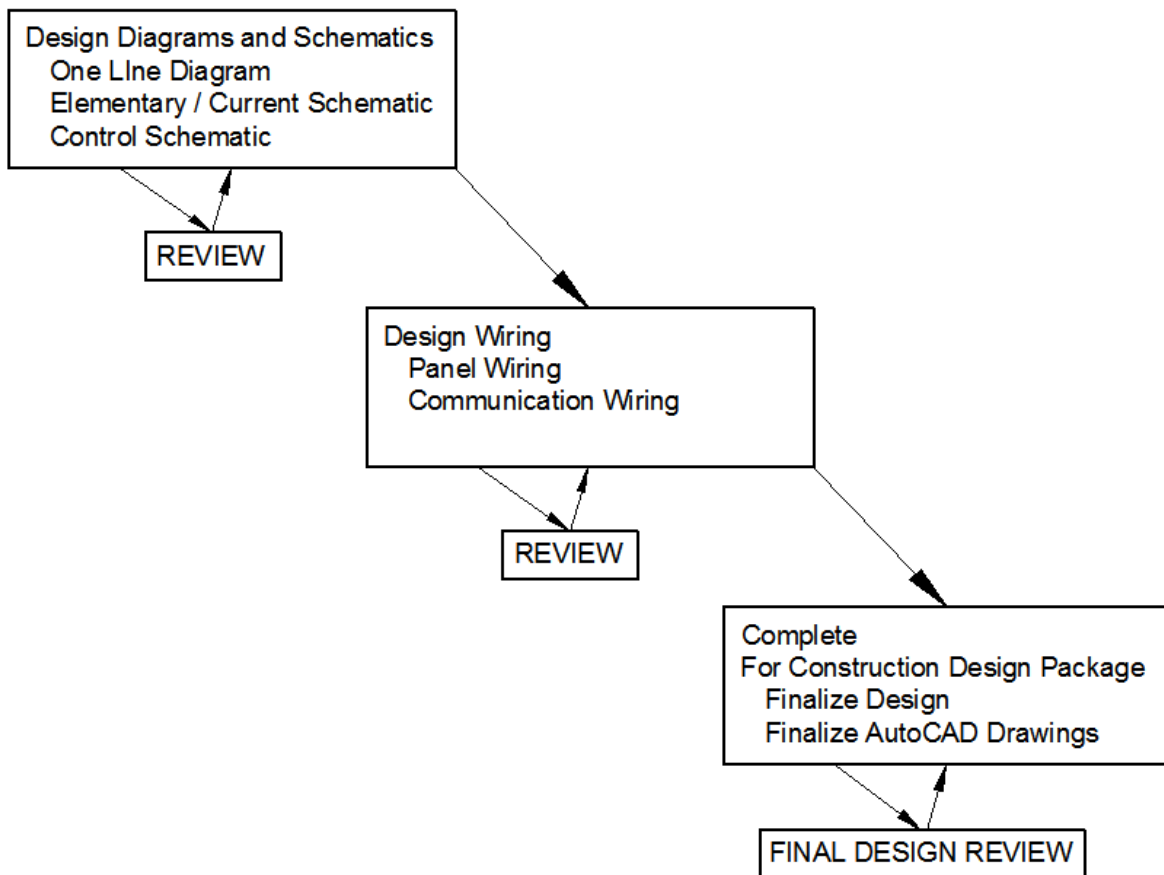

Figure 1: Concept Block Diagram

3. Design Description

The electromechanical relays to be replaced are on four different units, controlling four different switch gear, and powering different power plant equipment.

3.1. System input/output Analysis

3.1.1. System Inputs

The inputs to the new relay equipment will be very similar to the existing relays. AC line currents, AC bus voltages, 125VDC to power the relay, alarms, and breaker status will be brought into the SEL relay. The relay will use its programming to determine multiple functions and actions including tripping or closing the switchgear.

3.1.2. System Outputs

The outputs are similar to the relay inputs in that they will remain similar to the existing relay equipments outputs. The outputs will be switchgear trip and close, relay alarm, and communications.

3.2. User Interface Specifications

The primary software used for this project is AutoCAD. The CAD files will work as specified in the CIPCO CAD standard. These will be saved as .dwg file types and printed to .pdf. Fonts, layering, colors, title blocks, and additional items are covered in the CAD standard. The design review will cover both the electrical design as well as the drafting details.

3.3. Hardware/software Specifications

This project is software based, in that no physical product will be delivered. The project will be primarily designed in AutoCAD software. Other software used will be Microsoft products and Adobe Acrobat. No specialized software will be required and all CIPCO CAD standards will be followed.

3.4. Simulations and Modeling

All design drawings will be completed in AutoCAD and printed to pdf for review and for final construction drawings. These reviews will act as our testing grounds to produce a theoretical functioning design that meets industry standards. Arc flash calculations will be completed in Excel for ease of use and repeatability. Simulations and relay testing are out of scope for this project.

3.5. Implementation Issues Challenges

There are many challenges to this project. Some are based on lack of experience with this type of equipment and the environment that it is operated in. Other challenges can schedule conflicts and meeting required deadlines. Other challenges could be to balance cost versus benefit of the particular solution. All challenges will be met with a tenacious determination and a wiliness to learn.

3.6. Testing, Procedures and Specifications

No formal testing or simulations will be completed during this project and are considered out of scope. This design will be heavily reviewed to insure all industry standards, and regulations will be met and followed.

4. Design Decisions and Justifications

Standard drawings will be used and provided by CIPCO to help progress the project and understanding of the equipment.

4.1. One Line Diagram

The one line diagram is a simplified representation of the entire system. It uses industry standard symbols and IEEE device numbers to convey the equipment and the function of the equipment.

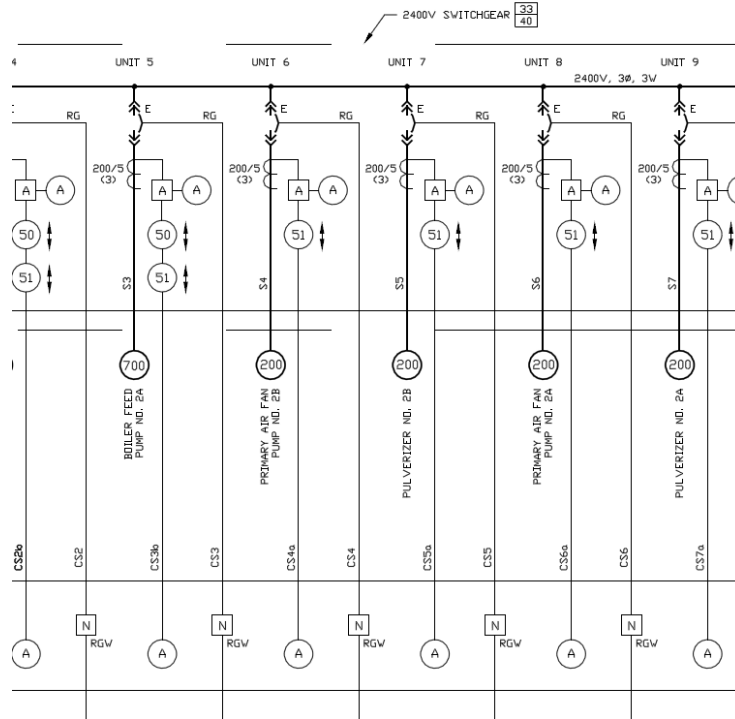

Figure 2: One Line Diagram

4.2. Elementary / Current Diagram

The elementary / current diagram is a simplified representation of the switchgear. The diagram show primarily how the current transformer is connected to the protective relaying, metering equipment, and phasing.

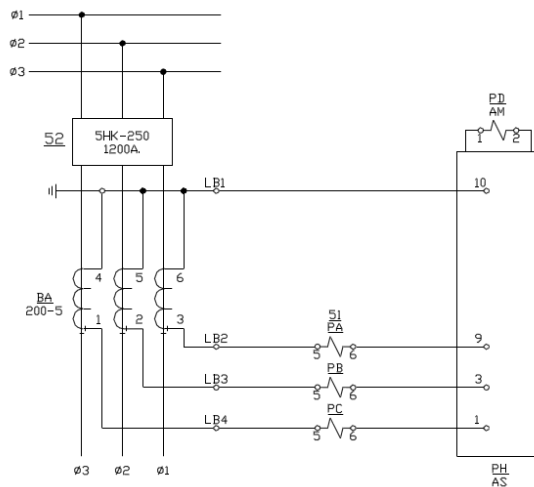

Figure 3: Elementary / Current Diagram

4.3. Control Diagram

The control diagram shows how the switchgear and relay equipment work together in a simplified diagram demonstrating its function. The diagram shows inputs and outputs of the relay, contacts of the breaker, and the close and trip portions of the control circuit. In general, it gives an overall picture of the workings between the equipment and a general understanding of how the equipment operates.

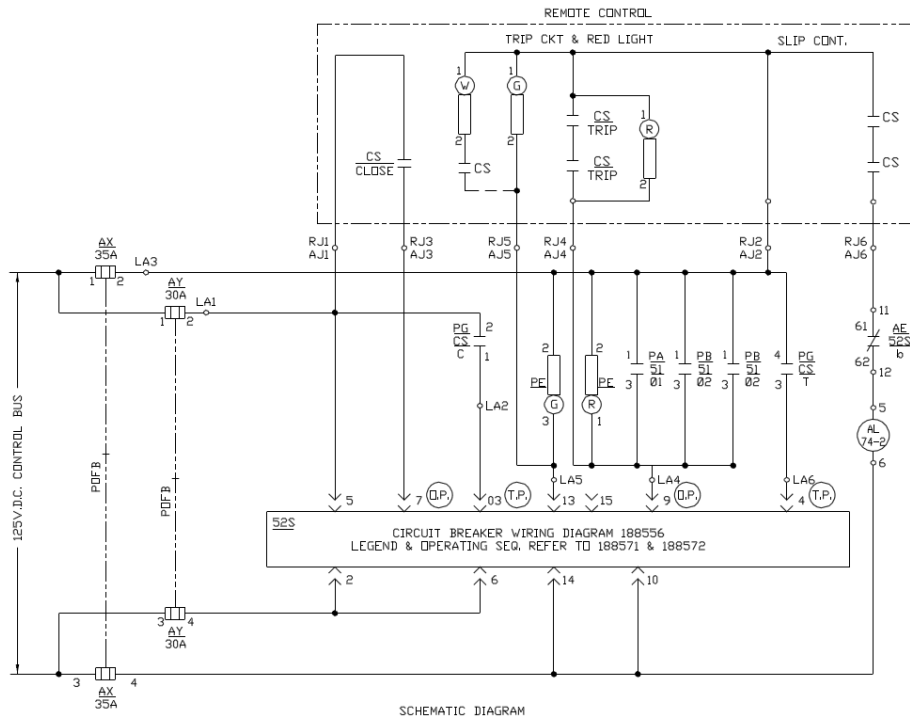

Figure 4: Control Diagram

4.4. Panel Wiring

Panel wiring is a diagram of how and where the equipment is wired together. The wiring should follow the functional representation shown in the control diagram and the other schematics.

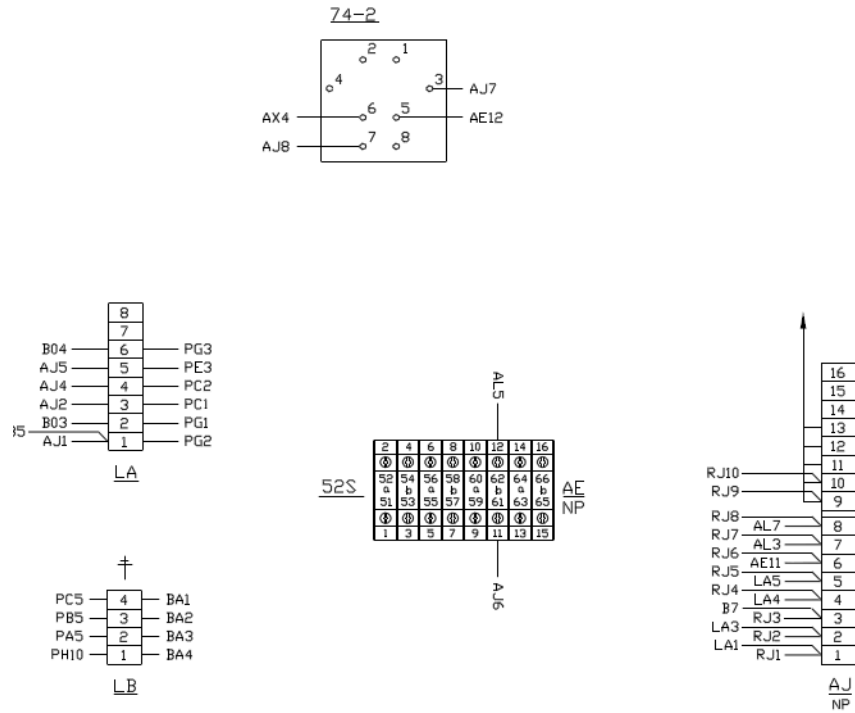

Figure 5: Panel Wiring

4.5. Communication Wiring

Communication wiring helps show what and how equipment is wired together. Some systems have functional schematics demonstrating how the equipment works together.

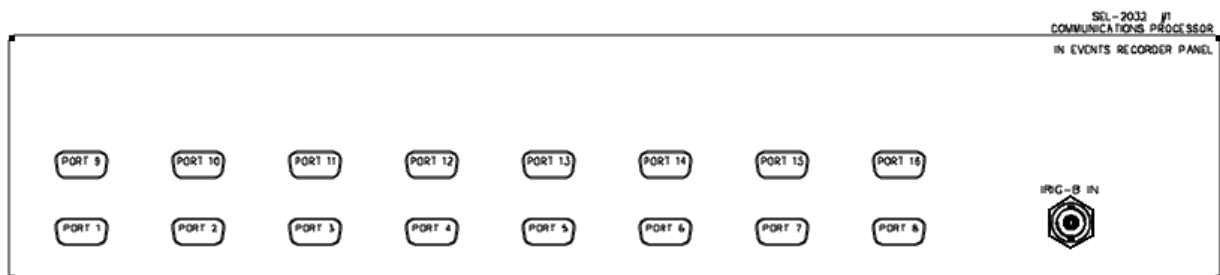

Figure 6: Communication Wiring

5. Work Plan

Below is the proposed.

Power Plant - Relay Replacement

Iowa State EE Senior Design - December 2015

Group: Dec15-22

Dan Dye - 4/25/15

Key Activities	Weeks - Spring 2015														
	1	2	3	4	5	6	7	8	9	10	11	12	13	14	15
Spring															
Develop Project Scope															
Develop Project Plan															
Develop Man-hour Budget															
Gantt Chart															
Design Relay One Line Diagram															
Design Elementary Diagram / Current Schematic															
Design Control Schematic															
Design Panel Wiring															
Design Communication processor Wiring															
Design Review															
Arc Flash Calculation															
Arc Flash Design Review															
Safe Operation Engineering Solutions															
Safe Operation Engineering Solutions Design Review															
Completion of Project Report															
Presentation Practice / Presentation															

Key Activities	Weeks - Fall 2015														
	1	2	3	4	5	6	7	8	9	10	11	12	13	14	15
Fall															
Design Elementary Diagram / Current Schematic															
Design Control Schematic															
Design Panel Wiring															
Design Review															
Relay Replacement Design Construction Package															
Relay Replacement Design Function															
Arc Flash Calculation Analysis															
Arc Flash Calculation Compliance Regulations															
Arc Flash Analysis Review															
Safety Operation Solutions Compliance Regulations															
Safety Operation Solutions Cost Estimates															
Safety Operation Solutions Operation Guild															
Safety Operation Review															
Completion of Final Project Report															
Design of Project Poster															
Presentation Practice															
Presentation															

Table 1: Work Schedule - Gantt chart

6. Conclusion

This senior design project has helped me learn a lot while working on the relay replacement, arc flash calculation and analysis, and safe solutions for operating switchgear. I have a better understanding of relay protection, power equipment, and the detail involved in the engineering and design process.

7. Engineering Diagrams

7.1. Switch Gear Diagrams

7.1.1. One Line Diagram

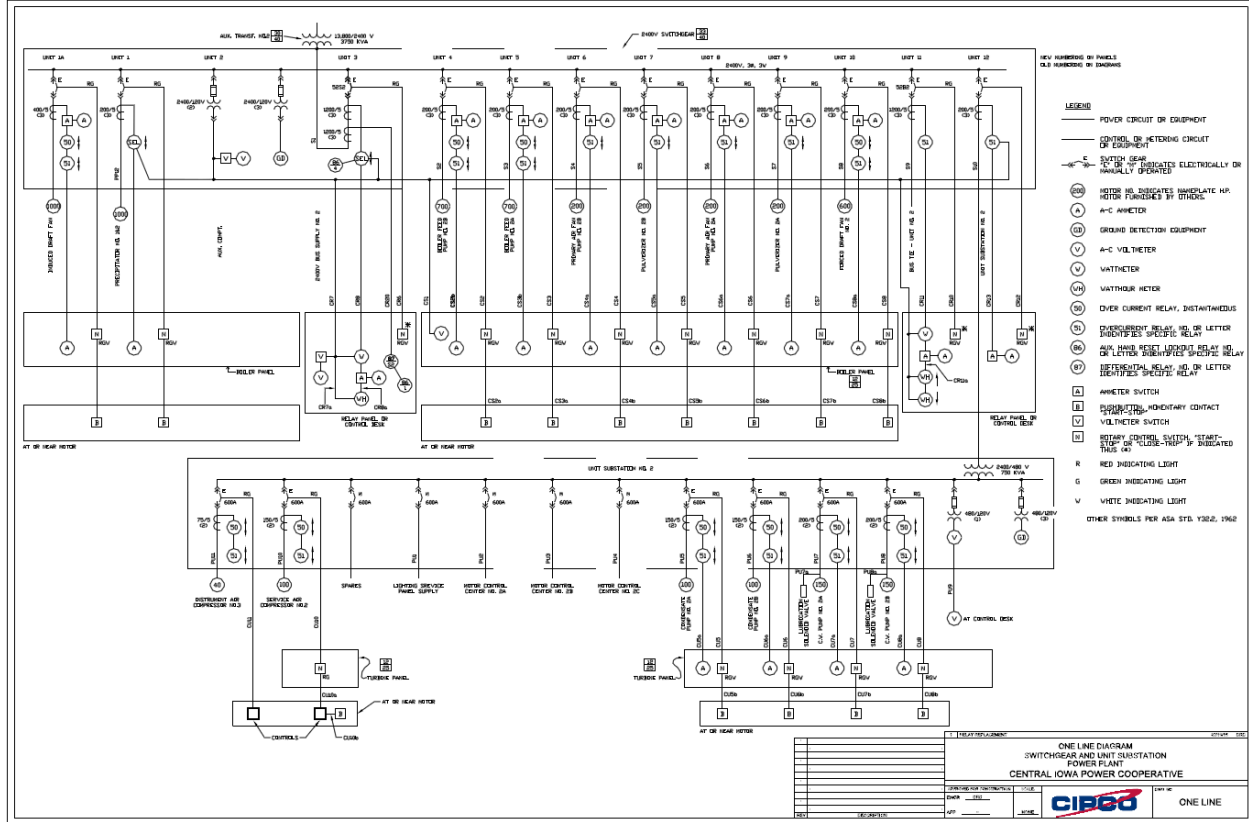

Figure 7: One Line Diagram

7.1.2. Power Plant – Unit #6 Diagram

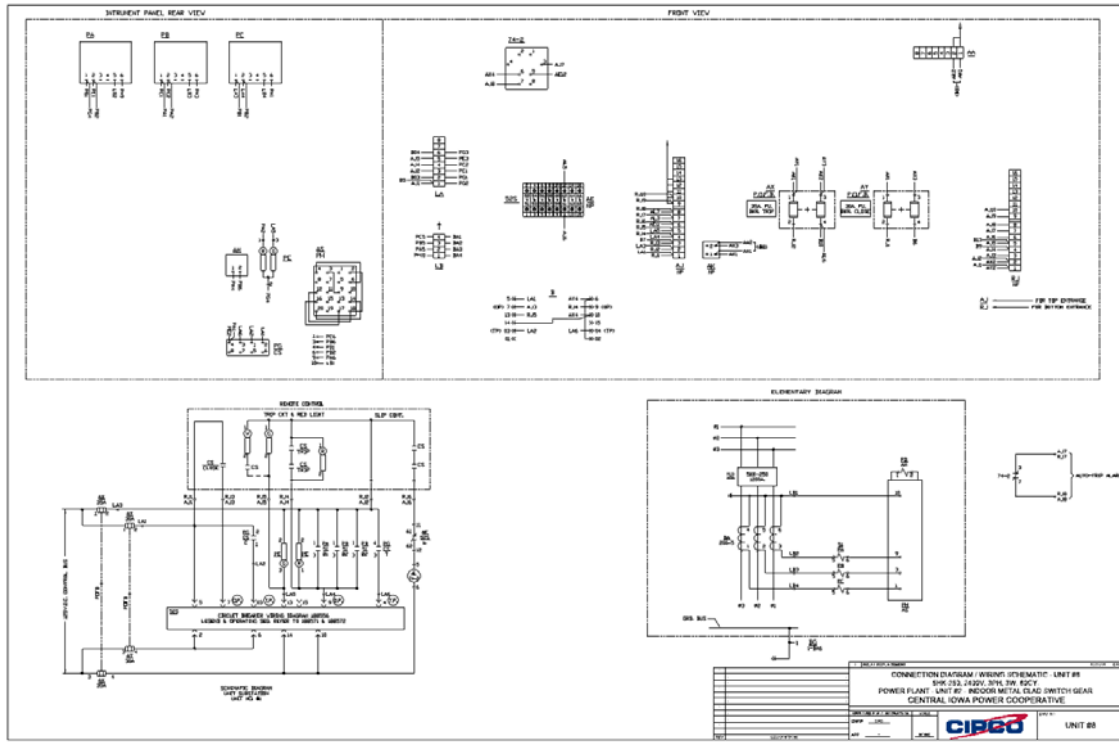

Figure 8: Connection Diagram / Wiring Schematic

7.2. Standard Drawings

7.2.1. Title Block

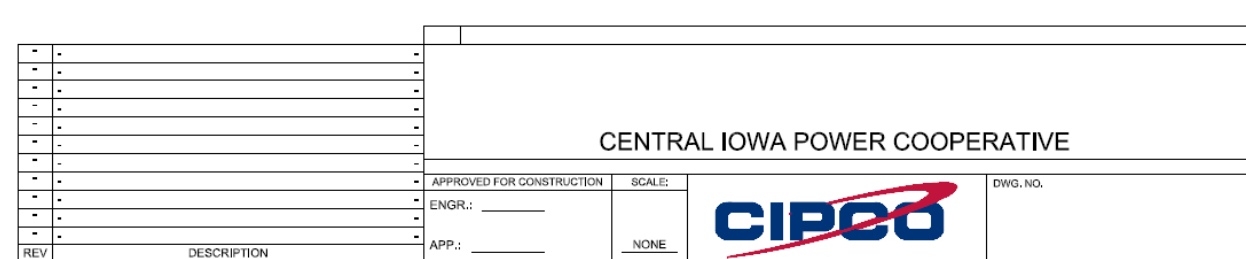

Figure 9: Standard Title Block

7.2.2. Standard Relay Wiring Diagram

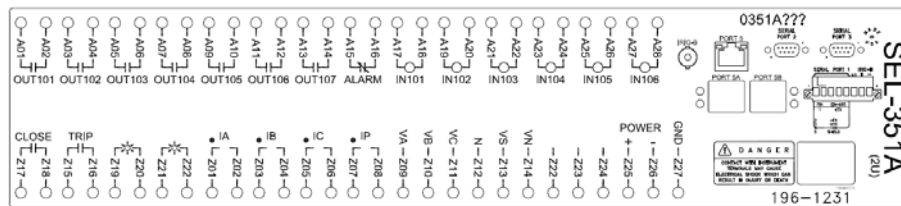

Figure 10: Standard Relay Wiring Diagram

7.2.3. CIPCO AutoCAD Standard Summary

The CIPCO AutoCAD standard is too detailed for this document. The purpose of the standard is to define information and procedures to assure the accurate and consistent work. The standard details items like drawing numbers, file naming, line types, title block, and construction drawings. These standards will be adhered to while completing this project.